

ASHLEY POWER LTD.
580-586 ASHLEY
ROAD
PARKSTONE
POOLE
DORSET, BH14 0AQ

ASHLEY POWER

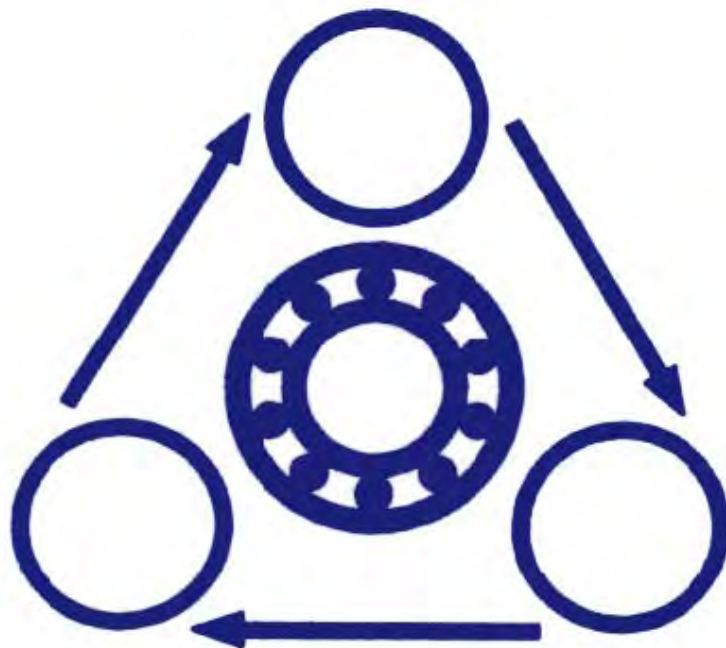

WORM GEAR UNIT CATALOGUE



ASHLEY POWER



WORM GEAR UNITS



CHM



CHME



CHMRE



CHMR



Worm Gear Unit Contents

Gearbox Dimensions.....	H4
Gearbox Performance.....	H5
Gearbox Technical Specifications.....	H6
Gearbox Combination Dimensions.....	H7
Gearbox Combination Performance.....	H8
Torque Arms, Single & Double Output Shaft Kits.....	H9

Please note: At Ashley Power we take care to ensure that all information is correct at time of printing however some errors and omissions excepted.



CHM - CHMR - CHME - CHMRE DIMENSIONS

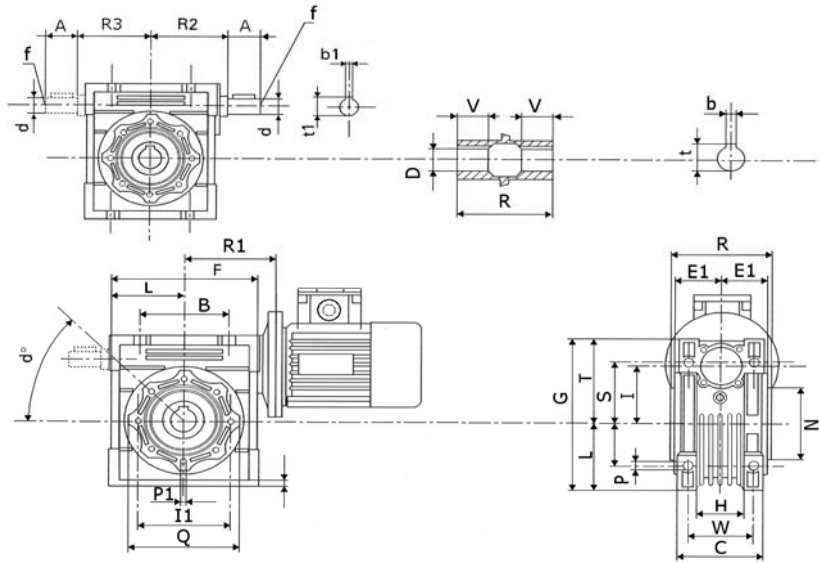

Unit Type	B	A	F	D (H7)	d (j6)	G	H	R1	R	R2	R3	L	I	C	I1	N (h8)	E1	P	Q
030	54	20	80	14	9	97	32	55	63	51	45	40	30	56	65	55	29	6.5	75
040	70	23	100	18	11	121.5	43	70	78	60	53	50	40	71	75	60	36.5	6.5	87
050	80	30	120	25	14	144	49	80	92	74	64	60	50	85	85	70	43.5	8.5	100
063	100	40	144	25	19	174	67	95	112	90	75	72	63	103	95	80	53	8.5	110
075	120	50	172	28	24	205	72	112.5	120	105	90	86	75	112	115	95	57	11	140
090	140	50	208	35	24	238	74	129.5	140	125	108	103	90	130	130	110	67	13	160
110	170	60	252.5	42	28	295	-	160	155	142	135	127.5	110	144	165	130	74	14	200
130	200	80	292.5	45	30	335	-	180	170	162	155	147.5	130	155	215	180	81	16	250

Unit Type	S	T	U	V	Z	W	P1	d°	b	b1	f	t	t1	Weight in kg. excluding motor
030	44	57	5.5	21	27	44	M6x11(n.4)	0°	5	3	-	16.3	10.2	1.2
040	55	71.5	6.5	26	35	60	M6x8(n.4)	45°	6	4	-	20.8	12.5	2.3
050	64	84	7	30	40	70	M8x10(n.4)	45°	8	5	M6	28.3	16.0	3.5
063	80	102	8	36	50	85	M8x14(n.4)	45°	8	6	M6	28.3	21.5	6.2
075	93	119	10	40	60	90	M8x14(n.4)	45°	8	8	M8	31.3	27.0	8.5
090	102	135	11	45	70	100	M10x18(n.4)	45°	10	8	M8	38.3	27.0	12
110	125	167.5	14	50	85	115	M10x18(n.4)	45°	12	8	M10	45.3	31.0	35
130	140	187.5	15	60	100	120	M12x21(n.4)	45°	14	8	M10	48.8	33.0	53

If a dimension is critical to your application please contact our sales department for confirmation.
Please note : errors and omissions excepted.



CHM PERFORMANCE WITH 4-POLE MOTORS

1400 REVS. INPUT

CHM 30

i=ratio	n2 r/min	Kw=p1	Nm=T2	f.s.
7.5	186.7	0.22	9	2.1
10	140.0	0.22	11	1.6
15	93.3	0.22	16	1.0
20	70.0	0.22	20	0.9
25	56.0	0.18	20	1.0
30	46.7	0.18	22	0.9
40	35.0	0.18	21	0.8
50	28.0	0.18	19	0.8
60	23.3	0.09	18	0.9
80	17.5	0.09	13	0.9

CHM 063

i=ratio	n2 r/min	Kw=p1	Nm=T2	f.s.
7.5	186.7	1.50	67.4	1.8
10	140.0	1.50	88.6	1.4
15	93.3	1.50	126	1.1
20	70.0	1.50	164	0.8
25	56.0	1.10	145	0.9
30	46.7	1.10	165	1.0
40	35.0	0.75	143	1.0
50	28.0	0.55	122	1.1
60	23.3	0.55	138	0.9
80	17.5	0.37	114	1.1
100	14.0	0.37	127	0.9

CHM 110

i=ratio	n2 r/min	Kw=p1	Nm=T2	f.s.
7.5	186.7	7.50	344	1.6
10	140.0	7.50	453	1.3
15	93.3	7.50	659	1.0
20	70.0	5.50	635	1.0
25	56.0	4.00	573	1.2
30	46.7	4.00	645	1.1
40	35.0	3.00	636	1.1
50	28.0	3.00	764	0.9
60	23.3	2.20	645	1.0
80	17.5	1.50	546	0.9
100	14.0	1.10	470	1.0

CHM 040

i=ratio	n2 r/min	Kw=p1	Nm=T2	f.s.
7.5	186.7	0.55*	22	1.6
10	140.0	0.55*	30	1.4
15	93.3	0.55*	44	0.9
20	70.0	0.55*	38	1.0
25	56.0	0.37	45	0.9
30	46.7	0.37	52	0.8
40	35.0	0.25	43	0.9
50	28.0	0.22	44	0.9
60	23.3	0.18	42	0.8
80	17.5	0.18	36	0.8
100	14.0	0.18	35	0.8

CHM 075

i=ratio	n2 r/min	Kw=p1	Nm=T2	f.s.
7.5	186.7	4.00	180	1.0
10	140.0	4.00	237	0.8
15	93.3	3.00	260	0.8
20	70.0	1.50	167	1.2
25	56.0	1.50	204	1.0
30	46.7	1.50	232	1.0
40	35.0	1.10	214	1.0
50	28.0	0.75	176	1.2
60	23.3	0.75	199	1.0
80	17.5	0.55	178	1.1
100	14.0	0.55	203	0.9

CHM 130

i=ratio	n2 r/min	Kw=p1	Nm=T2	f.s.
7.5	186.7	7.50	348	2.2
10	140.0	7.50	455	1.8
15	93.3	7.50	660	1.2
20	70.0	7.50	877	1.0
25	56.0	7.50	1071	0.9
30	46.7	7.50	1225	0.8
40	35.0	5.50	1173	0.9
50	28.0	4.00	1023	0.9
60	23.3	3.00	886	1.1
80	17.5	3.00	1112	0.8
100	14.0	1.50	652	1.1

CHM 050

i=ratio	n2 r/min	Kw=p1	Nm=T2	f.s.
7.5	186.7	0.75	33.3	2.0
10	140.0	0.75	43.9	1.6
15	93.3	0.75	62.6	1.2
20	70.0	0.75	80	0.9
25	56.0	0.55	70	1.0
30	46.7	0.55	80	1.0
40	35.0	0.37	67	1.1
50	28.0	0.37	78	0.9
60	23.3	0.37	87	0.8
80	17.5	0.25	70	0.9
100	14.0	0.18	59	0.9

CHM 090

i=ratio	n2 r/min	Kw=p1	Nm=T2	f.s.
7.5	186.7	4.00	184	1.5
10	140.0	4.00	242	1.3
15	93.3	4.00	351	1.1
20	70.0	4.00	456	0.8
25	56.0	3.00	417	0.8
30	46.7	3.00	478	0.9
40	35.0	1.50	306	1.2
50	28.0	1.50	367	1.0
60	23.3	1.50	421	0.8
80	17.5	0.75	257	1.1
100	14.0	0.75	300	0.9

* SIZE 71 MOTORS

If a dimension is critical to your application please contact our sales department for confirmation.

Please note : errors and omissions excepted.

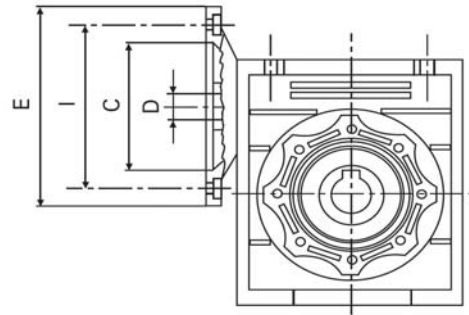

Gearbox Technical Specifications

Unit	Motor Frame Size	Flange Dimensions			Speed Ratio from 7.5:1 to 100:1										
		C	I	E	7,5	10	15	20	25	30	40	50	60	80	100
D Input Motor Shaft Sizes (mm)															
CHM 025	56B14	50	65	80	9	9	9	9	9	9	9	9	9		
CHM 030	63B5	95	115	140	11	11	11	11	11	11	11	11			
	63B14	60	75	90											
	56B5	80	100	120	9	9	9	9	9	9	9	9	9	9	9
CHM 040	56B14	50	65	80											
	71B5	110	130	160	14	14	14	14	14	14					
	71B14	70	85	105											
	63B5	95	115	140	11	11	11	11	11	11	11	11	11	11	11
CHM 050	63B14	60	75	90											
	56B5	80	100	120								9	9	9	9
	80B5	130	165	200	19	19	19	19	19	19					
	80B14	80	100	120											
CHM 063	71B5	110	130	160	14	14	14	14	14	14	14	14	14	14	14
	71B14	70	85	105											
	63B5	95	115	140							11	11	11	11	11
	90B5	130	165	200	24	24	24	24	24	24					
	90B14	95	115	140											
	80B5	130	165	200	19	19	19	19	19	19	19	19	19	19	
CHM 075	80B14	80	100	120											
	71B5	110	130	160								14	14	14	14
	100/112B5	180	215	250	28	28	28								
	100/112B14	110	130	160											
	90B5	130	165	200	24	24	24	24	24	24	24	24			
	90B14	95	115	140											
CHM 090	80B5	130	165	200				19	19	19	19	19	19	19	19
	80B14	80	100	120								19	19	19	19
	100/112B5	180	215	250	28	28	28	28	28	28					
	100/112B14	110	130	160											
	90B5	130	165	200	24	24	24	24	24	24	24	24	24		
CHM 110	90B14	95	115	140											
	80B5	130	165	200										19	19
	132B5	230	265	300	38	38	38	38							
	100/112B5	180	215	250	28	28	28	28	28	28	28	28	28		
	100/112B14	110	130	160											
CHM 130	90B5	130	165	200										24	24
	132B5	230	265	300	38	38	38	38	38	38	38				
	100/112B5	180	215	250							28	28	28	28	28
	100/112B14	110	130	160											

If a dimension is critical to your application please contact our sales department for confirmation.
Please note : errors and omissions excepted.



**DIMENSIONS OF
COMBINED GEARS
CHM-CHM/CHMR-CHM**

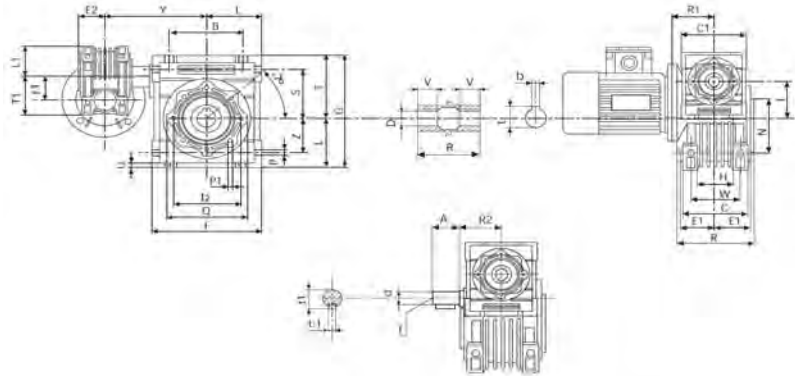

CHM-CHM	B	A	F	C1	D(H7)	d(j6)	G	H	R1	R	R2	L	L1	I
030/040	70	20	100	80	18	9	121.5	43	55	78	51	50	40	40
030/050	80	20	120	80	25	9	144	49	55	92	51	60	40	50
030/063	100	20	144	80	25	9	174	67	55	112	51	72	40	63
040/075	120	23	172	100	28	11	205	72	70	120	60	86	50	75
040/090	140	23	208	100	35	11	238	74	70	140	60	103	50	90
050/110	170	30	252.5	120	42	14	295	-	80	155	74	127.5	60	110
063/130	200	40	292.5	144	45	19	335	-	95	170	90	147.5	72	130

CHM-CHM	I1	C	I2	N(H8)	E1	E2	P	Q	S	T	T1	U	V	Z
030/040	30	71	75	60	36.5	29	6.5	87	55	71.5	57	6.5	26	35
030/050	30	85	85	70	43.5	29	8.5	100	64	84	57	7	30	40
030/063	30	103	95	80	53	29	8.5	110	80	102	57	8	36	50
040/075	40	112	115	95	57	36.5	11	140	93	119	71.5	10	40	60
040/090	40	130	130	110	67	36.5	13	160	102	135	71.5	11	45	70
050/110	50	144	165	130	74	43.5	14	200	125	167.5	84	14	50	85
063/130	63	155	215	180	81	53	16	250	140	187.5	102	15	60	100

CHM-CHM	Y	W	P1	a	b	b1	f	t	t1	Weight in kg excluding motor
030/040	120	60	M6x8(n.4)	45°	6	3	-	20.8	10.2	3.9
030/050	130	70	M8x10(n.4)	45°	8	3	-	28.3	10.2	5.0
030/063	145	85	M8x14(n.8)	45°	8	3	-	28.3	10.2	7.8
040/075	165	90	M8x14(n.8)	45°	8	4	-	31.3	12.5	11.5
040/090	182	100	M10x18(n.8)	45°	10	4	-	38.3	12.5	15
050/110	225	115	M10x18(n.8)	45°	12	5	M6	45.3	16.0	39.2
063/130	245	120	M12x21(n.4)	45°	14	6	M6	48.8	21.5	70

If a dimension is critical to your application please contact our sales department for confirmation.
Please note : errors and omissions excepted.



CHM/CHM PERFORMANCE WITH 4 POLE MOTORS 1400 REVS. INPUT

CHM 030/040

i=ratio	n2 r/min	Kw=P1	Nm=T2
300	4.7	0.09*	70
400	3.5	0.09*	63
500	2.8	0.09*	57
600	2.3	0.09*	72
750	1.9	0.09*	72
900	1.6	0.09*	73
1200	1.2	0.09*	65
1500	0.9	0.09*	73
1800	0.8	0.09*	73
2400	0.6	0.09*	65

CHM 040/075

i=ratio	n2 r/min	Kw=P1	Nm=T2
300	4.7	0.37	405
400	3.5	0.25	336
500	2.8	0.25	307
600	2.3	0.18	362
750	1.9	0.18	391
900	1.6	0.18*	325
1200	1.2	0.18*	359
1500	0.9	0.09	360
1800	0.8	0.09	404
2400	0.6	0.09*	330

CHM 050/110

i=ratio	n2 r/min	Kw=P1	Nm=T2
300	4.7	0.75	871
400	3.5	0.75	1013
500	2.8	0.55	984
600	2.3	0.55	1062
750	1.9	0.55	1128
900	1.6	0.37	1079
1200	1.2	0.25	943
1500	0.9	0.25	1064
1800	0.8	0.25	1075
2400	0.6	0.18	1001

CHM 030/050

i=ratio	n2 r/min	Kw=P1	Nm=T2
300	4.7	0.18	142
400	3.5	0.18	127
500	2.8	0.09	123
600	2.3	0.09	143
750	1.9	0.09	148
900	1.6	0.09*	141
1200	1.2	0.09*	118
1500	0.9	0.09*	139
1800	0.8	0.09*	155
2400	0.6	0.09*	124

CHM 040/090

i=ratio	n2 r/min	Kw=P1	Nm=T2
300	4.7	0.37	405
400	3.5	0.37	523
500	2.8	0.37	550
600	2.3	0.37	605
750	1.9	0.25	538
900	1.6	0.25	533
1200	1.2	0.18	629
1500	0.9	0.18	588
1800	0.8	0.18*	492
2400	0.6	0.18*	625

CHM 063/130

i=ratio	n2 r/min	Kw=P1	Nm=T2
300	4.7	1.50	1789
400	3.5	1.10	1519
500	2.8	1.10	1629
600	2.3	0.75	1631
750	1.9	0.75	1804
900	1.6	0.75	1826
1200	1.2	0.55	1705
1500	0.9	0.37	1674
1800	0.8	0.37	1698
2400	0.6	0.25	1624

CHM 030/063

i=ratio	n2 r/min	Kw=P1	Nm=T2
300	4.7	0.22	210
400	3.5	0.18	222
500	2.8	0.18	205
600	2.3	0.18*	208
750	1.9	0.18*	216
900	1.6	0.09	200
1200	1.2	0.09	236
1500	0.9	0.09*	204
1800	0.8	0.09*	202
2400	0.6	0.09*	220

N.B. the powers marked with * are higher than those that the gear allows, therefore the applicative choice must be made in accordance with the torque and not the power

The gear ratios are those most frequently requested. It is possible to obtain multiple combinations using the various ratios of the two single gears.

If a dimension is critical to your application please contact our sales department for confirmation.
Please note : errors and omissions excepted.

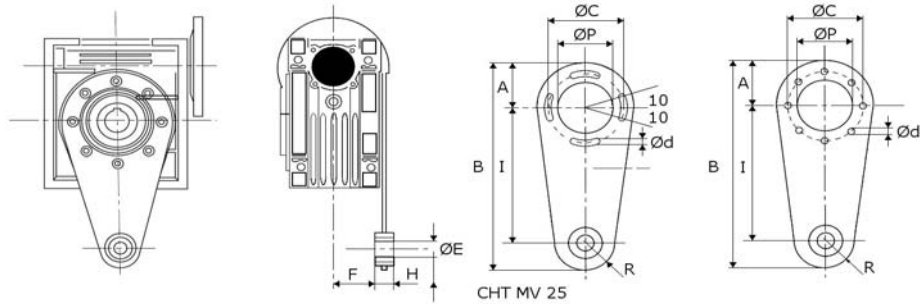

TORQUE ARM

TYPE	I	R	F	H	ØE	A	B	ØC	Ød	ØP	Nº	Weight per kit kg.
CHT MV 25*	70	15	17.5	14	8	33.5	118.5	55	7	45	4	0.17
CHT MV 30*	85	15	24	14	8	38	138	65	7	55	8	0.18
CHT MV 40	100	18	31.5	14	10	44	162	75	7	60	8	0.24
CHT MV 50	100	18	38.5	14	10	50	168	85	9	70	8	0.27
CHT MV 63	150	18	49	14	10	55	223	95	9	80	8	0.57
CHT MV 75	200	30	47.5	25	20	70	300	115	9	95	8	1.10
CHT MV 90	200	30	57.5	25	20	80	310	130	11	110	8	1.26
CHT MV 110	250	35	62	30	25	100	385	165	11	130	8	1.92
CHT MV 130/150	250	35	69	30	25	125	410	215	14	180	8	2.23

* Without vibration resistant bushing
 The arm anchoring point of the torque arm is equipped with a vibration resistant bushing

SINGLE OUTPUT SHAFT KIT



TYPE	A	Ød	B	b	t1	R	L	d2	Weight per kit kg
CHT MVS 25	23	11	25.5	4	12.5	55.5	81	-	0.07
CHT MVS 30	30	14	32.5	5	16	69.5	102	M6x16	0.14
CHT MVS 40	40	18	43	6	20.5	85	128	M6x16	0.27
CHT MVS 50	50	25	53.5	8	28	99.5	153	M10x22	0.60
CHT MVS 63	50	25	53.5	8	28	119.5	173	M10x22	0.67
CHT MVS 75	60	28	63.5	8	31	128.5	192	M10x22	0.94
CHT MVS 90	80	35	84.5	10	38	149.5	234	M12x28	1.79
CHT MVS 110	80	42	84.5	12	45	164.5	249	M16x35	2.70
CHT MVS 130	80	45	85	14	48.5	180	265	M16x35	3.60

DOUBLE OUTPUT SHAFT KIT

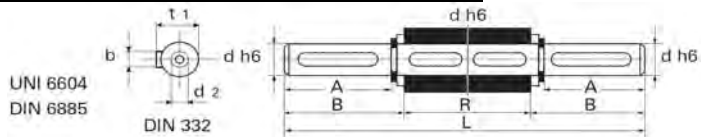

TYPE	A	Ød	B	R	b	t1	L	d2	Weight per kit kg
CHT MVD 25	23	11	25.5	50	4	12.5	101	-	0.11
CHT MVD 30	30	14	32.5	63	5	16	128	M6x16	0.16
CHT MVD 40	40	18	43	78	6	20.5	164	M6x16	0.34
CHT MVD 50	50	25	53.5	92	8	28	199	M10x22	0.75
CHT MVD 63	50	25	53.5	112	8	28	219	M10x22	0.84
CHT MVD 75	60	28	63.5	120	8	31	247	M10x22	1.2
CHT MVD 90	80	35	84.5	140	10	38	309	M12x28	2.5
CHT MVD 110	80	42	84.5	155	12	45	324	M16x35	3.44
CHT MVD 130	80	45	85	170	14	48.5	340	M16x35	4.25

If a dimension is critical to your application please contact our sales department for confirmation.
 Please note : errors and omissions excepted.



ASHLEY POWER



Notes